

I-80 TRUCK/BUS CHAIN REQUIREMENTS



Trucks/Buses are permitted in chain control areas when equipped with chains or Automatic Traction Device (ATD) as indicated.

Trucks/Buses with cable-type chains with less than 1/2" cross links are legal in California. However, these vehicles may be restricted at times due to local conditions.

The Department of Transportation reserves the right to prohibit any vehicle from entering a chain control area when it is determined the vehicle will experience difficulty in safely traveling the area.



LEGEND

- Driving axle
- Non-driving axle
- Wheel with chains or ATD
- Wheel with no chains
- ★ Chains required on inside dual if possible
- ◆ Drive axle must be chained
- ▲ Chains on trailers may be staggered front and back
- Caltrans may require chains on all drive wheels if conditions warrant
- Both axles must be chained. (Four wheels with chains or ATD)

NOTES

- Trailers with brakes must have chains on one axle.
- Front-wheel drive vehicles must have chains on front (drive) axle.
- On any semi-trailer, only one set of chains is required regardless of number of axles.
- Chains are not required on tag axle.

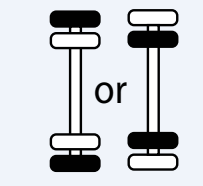

Acceptable on either axle of semi-trailers.

- Cable traction devices maybe held during severe conditions.
- Single-drive trucks with dual trailers may restricted during severe conditions.

Any vehicle not meeting requirements for Min.-Max. Program must use CA-Standard Chart Requirements



CALIFORNIA STANDARD CHAIN REQUIREMENTS TRUCKS AND BUSES

BUSES/RECREATIONAL VEHICLES

(Articulated buses must also chain outside wheels of last axle)

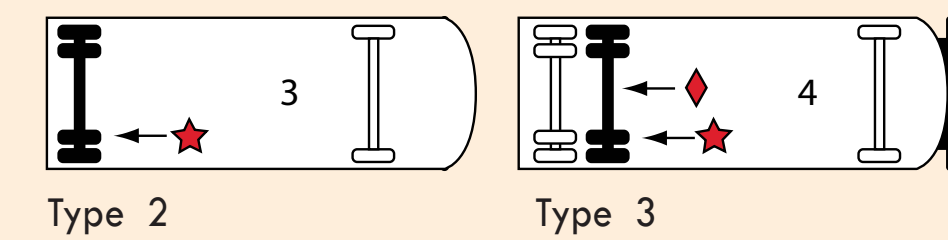

TRUCKS

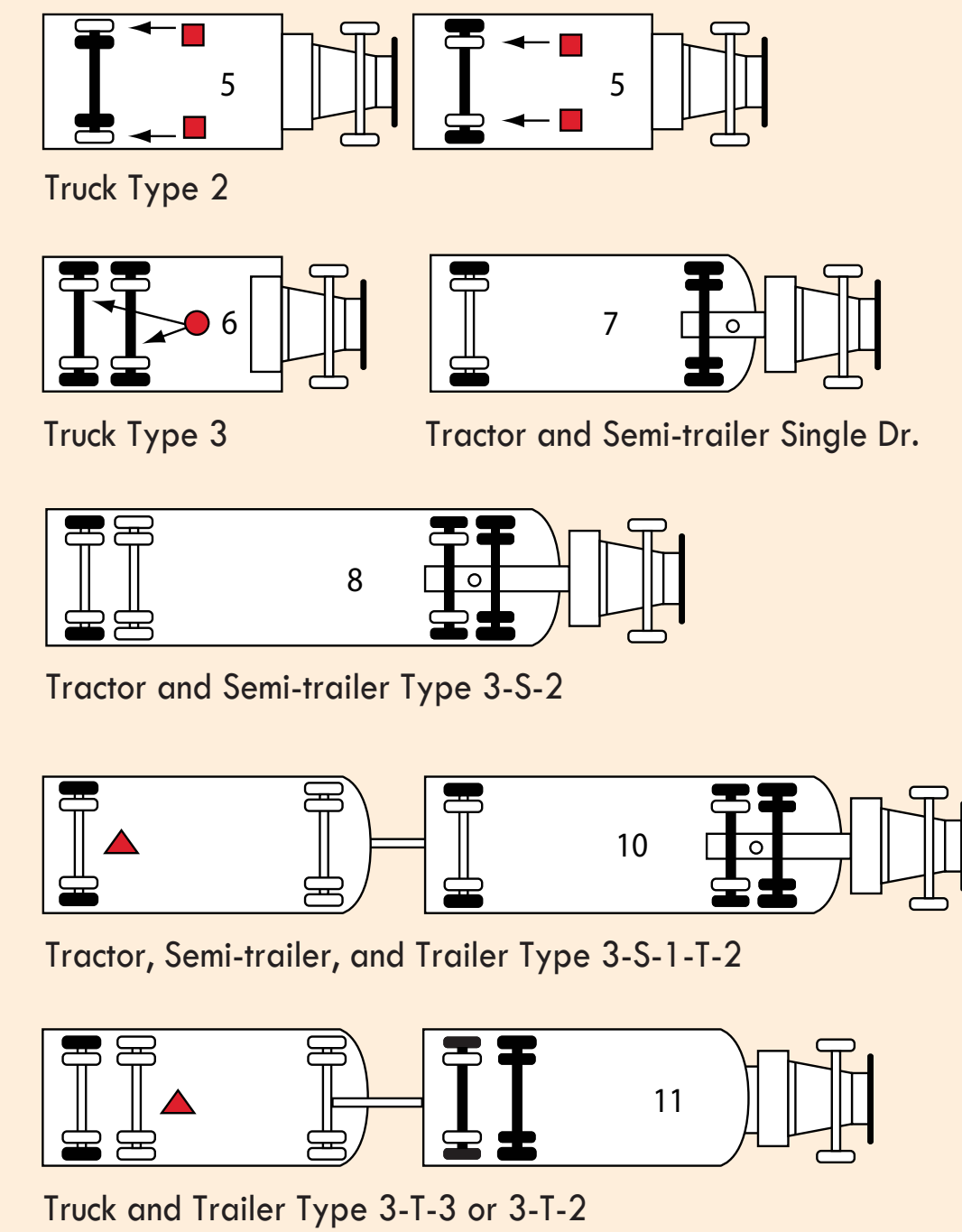

The following truck may be restricted when chains are required:

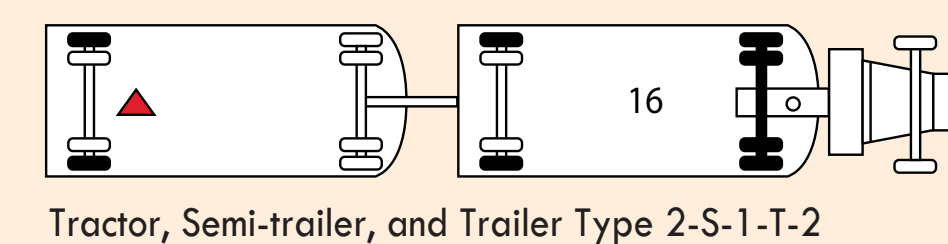

For questions regarding these configurations, please contact the Caltrans Maintenance Program at (916) 654-4470.

I-80 TRUCK MINIMUM - MAXIMUM PROGRAM - QUALIFICATIONS

- Must be a dual-drive axle truck (except Type 2 or 3 trucks bobtail or delivery vans)
- Chains or cables MUST have minimum 1/2" diameter crosslinks
- During minimum requirements adequate chains must be in possession to meet maximum requirements

Any truck not meeting requirements for Program must chain up to California Standard Chain Requirements

I-80 MINIMUM CHAIN REQUIREMENT PROGRAM TRUCKS

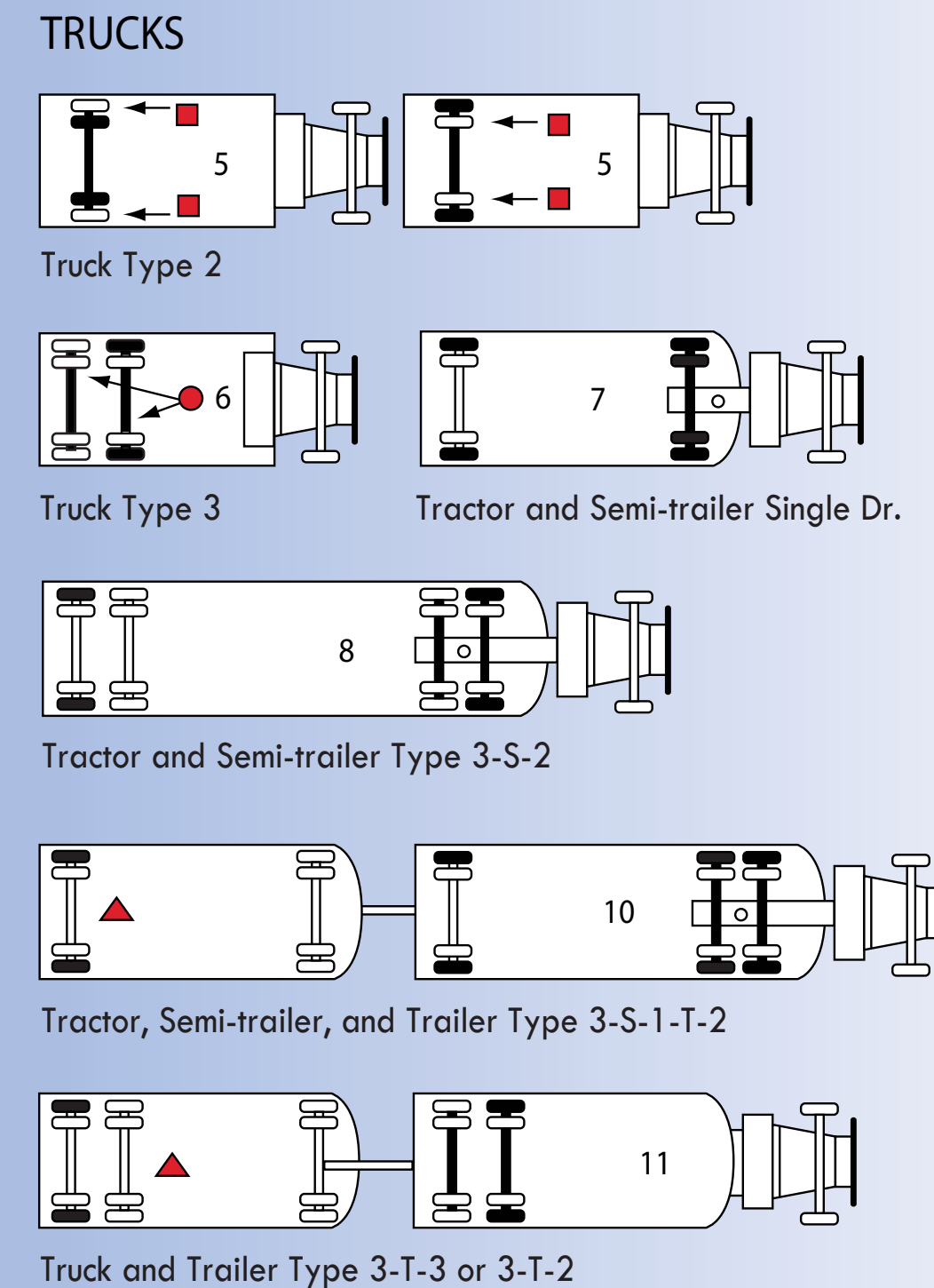

The following truck may be restricted when chains are required:

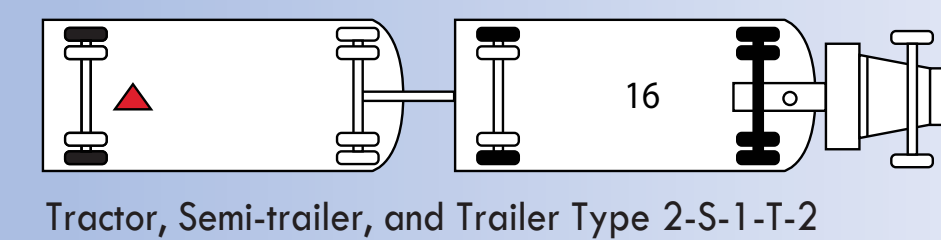

For questions regarding these configurations, please contact the Caltrans Maintenance Program at (916) 654-4470.

I-80 MAXIMUM CHAIN REQUIREMENT PROGRAM TRUCKS

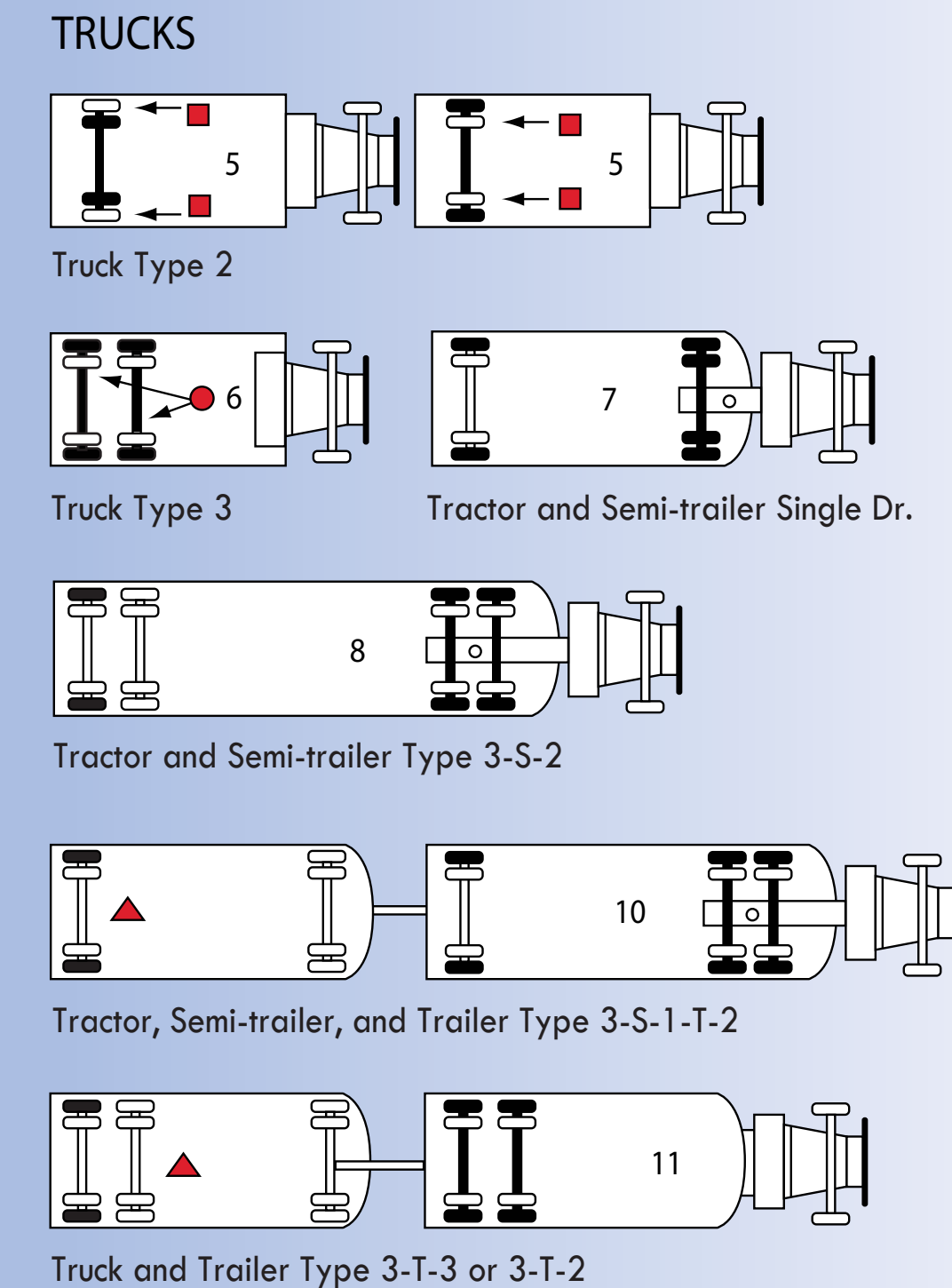

The following truck may be restricted when chains are required:

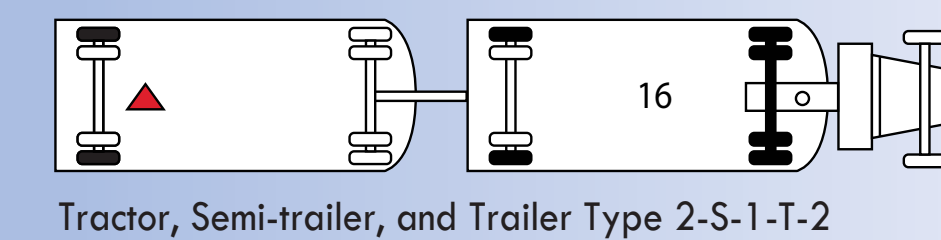

For questions regarding these configurations, please contact the Caltrans Maintenance Program at (916) 654-4470.